

NOTES:

1. RoHS: COMPLIANT

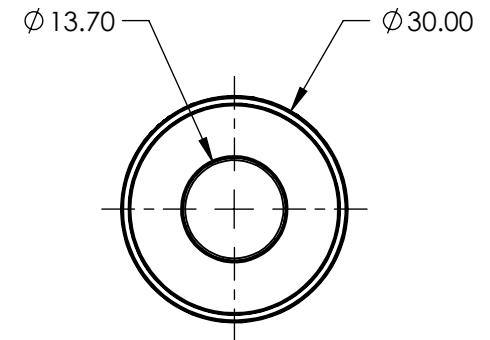
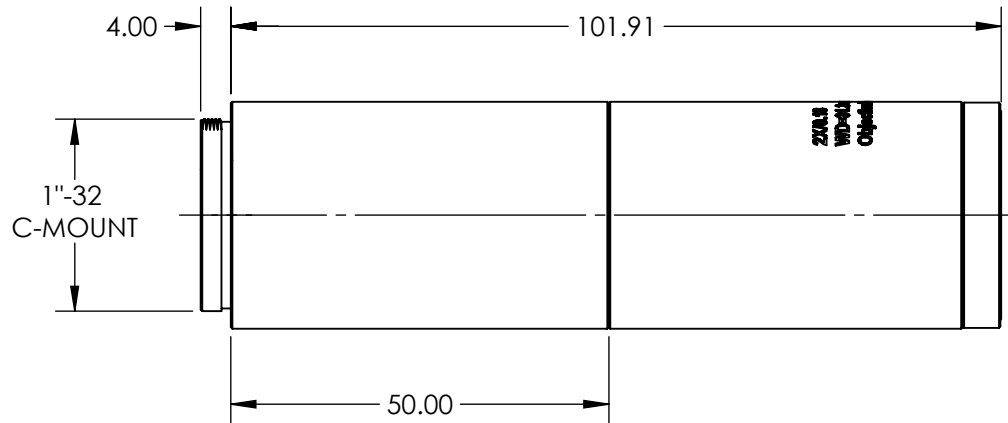

**FOR INFORMATION ONLY:
DO NOT MANUFACTURE
PARTS TO THIS DRAWING**

SPECIFICATIONS SUBJECT TO CHANGE WITHOUT NOTICE
DIMENSIONS ARE FOR REFERENCE ONLY

	VALUE
FIELD OF VIEW, 1/2" SENSOR	3.20 x 2.40mm
FIELD OF VIEW, 2/3" SENSOR	4.40 x 3.30mm
MAGNIFICATION	2X
MAX SENSOR FORMAT	2/3"
NUMERICAL APERTURE	0.12
WORKING DISTANCE	31.3
STYLE	FINITE CONJUGATE

THIRD ANGLE PROJECTION

ALL DIMS IN mm

EO® Edmund Optics®

TITLE

2X COMPACT ADJUSTABLE OBJECTIVE

DWG NO

88352

SHEET
1 OF 1