

NOTES:

1. SUBSTRATE:
VACUUM UV GRADE CaF2
2. SURFACE S2 TO BE PARALLEL WITH S1 TO <1 arcmin
3. COATING (APPLY ACROSS CLEAR APERTURE)
S1 & S2: R(AVG) ≤ 1.5% FROM 250-700nm @ 0° AOI
R(ABS) ≤ 1.0% FROM 350-450nm @ 0° AOI

4. FINE GRIND SURFACE

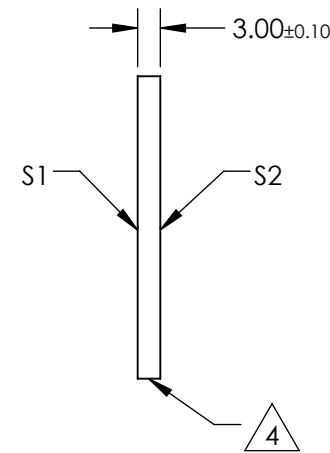
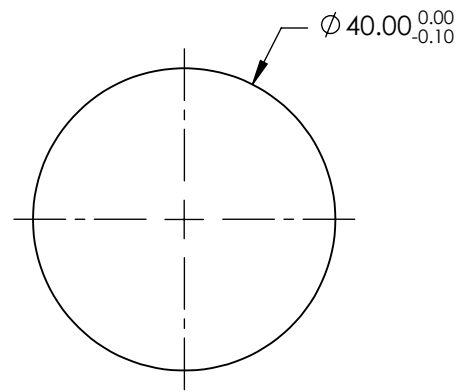
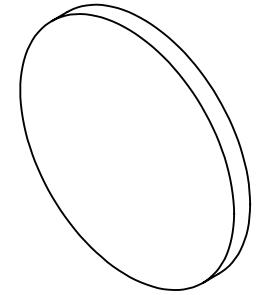

**FOR INFORMATION ONLY:
DO NOT MANUFACTURE
PARTS TO THIS DRAWING**

SPECIFICATIONS SUBJECT TO CHANGE WITHOUT NOTICE
DIMENSIONS ARE FOR REFERENCE ONLY

	S1	S2
SHAPE	PLANO	PLANO
SURFACE QUALITY	40-20	40-20
CLEAR APERTURE	Ø36.00	Ø36.00
BEVEL	PROTECTIVE AS NEEDED	PROTECTIVE AS NEEDED



ALL DIMS IN mm

EO® Edmund Optics®

TITLE

Ø40mm, UV - VIS, CALCIUM FLUORIDE WINDOW

DWG NO

14808

SHEET 1 OF 1