

|       |               |             |
|-------|---------------|-------------|
| F9J " | 89G7 F-DHC B. | B5A 9#85H9. |
|       |               |             |
|       |               |             |
|       |               |             |

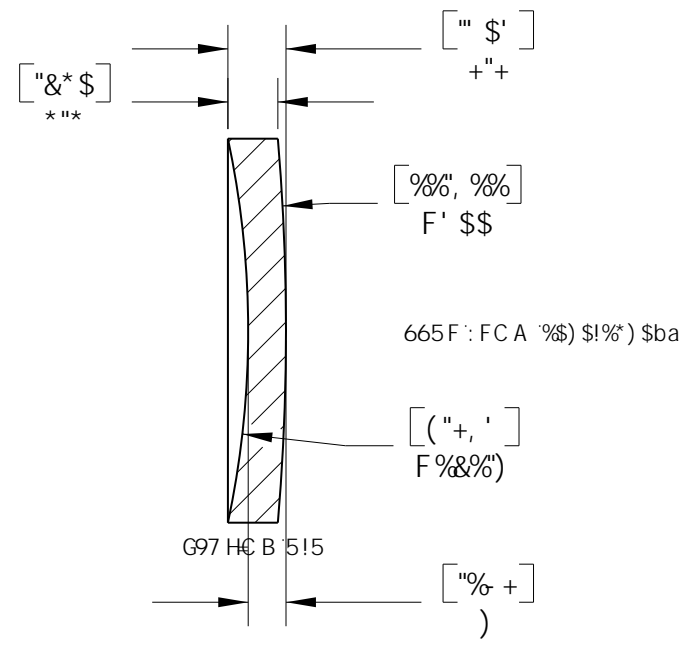
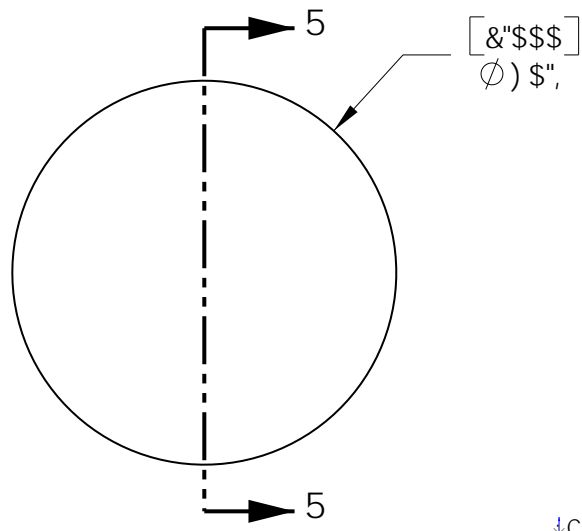

\*C 75@@B; Hk. !(\$"\$a a  
657?: C 75@ !' - +\"+a a  
-B 89L. %)%) '4 \*' ' ba  
89G= B' K 5J 9@B; Hk. ' \*' ' ba  
G7 F5H7 <#8 = .(' \$&\$  
8-5A 9HF HC @F 5B 7 9. Ž\$\"\$\$\$a a # \"\$\"\$a a  
7 @95F '5D9FH F 9. O- \$i  
7 9BHF 5HC B. ' '5F7 'A B  
7 9BHF 'Hk-? B 9CG HC @F 5B 7 9. '-\$\"%a a  
7 <5A: 9F '\$\"&\$a a '5H(') \$'5@G<5FD'98; 9G  
98: 9Hk-? B 9CG 5GG A B; 'G<5FD'98; 9  
5B 8; ∩ 9B '69. C F 97 <5A: 9F

BCH9.  
: CF 'B: CFA 5HC B 'CB@M  
BCH: CF 'A 5BI : 57H F-B;

5@I B+G; ∩ 9B 'B 'A @A 9HFG

|                                               |                                                 |                   |
|-----------------------------------------------|-------------------------------------------------|-------------------|
| <b>HC @F 5B 7 9G</b>                          | B5A 9                                           | 85H9              |
| 1 B @9GC H: 9FK @9 GD97 = 98.                 | 8F5K B                                          | 5D ) #8) #&\$ \$* |
| 8-A 9B GC BG 5F 9-B 'B7 <9G                   | 9B: '5DDF"                                      | HC ) #8) #&\$ \$* |
| @B 95F HC @F 5B 7 9G                          | A: '5DDF"                                       | HC ) #8) #&\$ \$* |
| ... Hk C D @5 7 9 8 97 -A 5 @ ± \$ \$ % \$    | <b>DFC DF -9 6 FM 5 B 8 7 C B: -8 9 B H 5 @</b> |                   |
| ... Hk F 99 D @5 7 9 8 97 -A 5 @ ± \$ \$ % \$ | Hk 9 B: CFA 5HC B 7 C B H 5 B 98 -B Hk G        |                   |
| 5B: 1 @5 F. '±' \$ π"                         | 8F5K B: '6Hk 9GC @9 DFC D9F HMC:                |                   |
| GI F: 57 9: B G<." & A = FC -B 7 <9G          | Hk C F @5 6Gz -B 7 " 5 B MF 9DF C 8I 7 HC B     |                   |
| D5F 5 @9 @CA. '\$ \$ \$ &                     | B D5F HC F 5G 5 K <C @K Hk C I H                |                   |
| : @5 B 9CG '\$ \$ \$ &                        | Hk 9K F #9B D9FA 6GC B C:                       |                   |
| GF 5 = <H 9CG '\$ \$ \$ &                     | Hk C F @5 6Gz -B 7 " 6 DFC <-6 +98"             |                   |
| 7 C B 7 9B HF = 7 H M '\$ \$ \$ &             |                                                 |                   |
| D9F D9B 8-7 1 @5 F H M '\$ \$ \$ &            |                                                 |                   |
| Hk F 95 8. 7 @5 GG &: #                       |                                                 |                   |

|                                                    |              |
|----------------------------------------------------|--------------|
| Hk C F @5 6Gz -B 7 " DC '6CL" **                   |              |
| B 9K HC B 'B >                                     |              |
| H# @.                                              |              |
| « ) \$\", a a '6? + 'B 9. 5HJ 9'A 9B -G7 I G @9B G |              |
| A 5H9F 5 @                                         | G#9 F9J "    |
| 6? +ž: fUXY '5                                     | 5 5          |
| G7 5 @. %%                                         | G< 99H% C: % |
| 8K ; " "BC "                                       | D5FH'BC "    |
| (- &\$!9\$%                                        | @ % @ @ !7   |