

Rev.	Description	Drawn	Date	Appr.
------	-------------	-------	------	-------

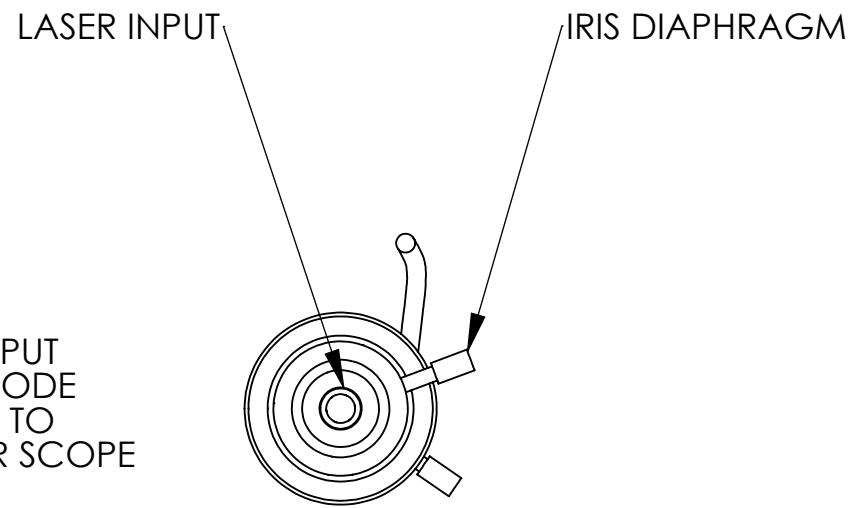
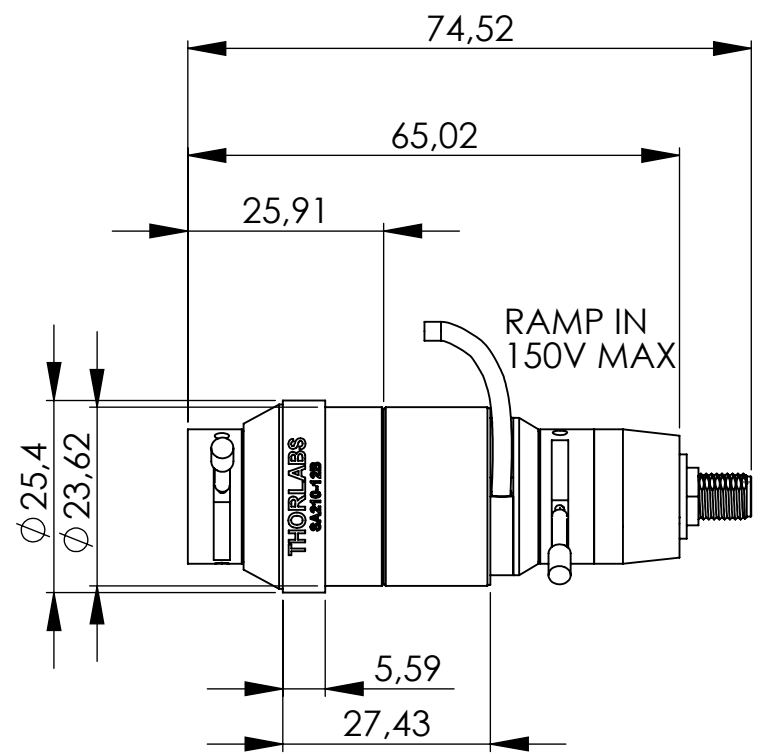

This drawing must not without our permission be copied, im-
 ported to a third party or otherwise used without authorisation.
 Contrainvention will be prosecuted.
 Denna handling är Thorlabs Sweden AB's egendom
 och får ej utan vårt medgivande kopieras, delges
 annan eller obehörigen användas.

INFORMATION ONLY, NOT FOR MANUFACTURING

Surface Treatment		Material		General Tolerance SS ISO-2768 fH		Weight 90 g	
Design	Drawn	Check	Sheet 1/1	Sheet Format A4	Scale 1:1		Rev. A
THORLABS Sweden AB Tel: +46 31 733 3000 Box 14194 Fax: +46 31 703 4045 SE-400 20 Göteborg							Date 2009-10-20
Scanning Fabry Perot 1275-2000nm SA210-12B, 10GHz FSR						Drawing no. 19505-E01	